

LIVING IN JAZZ

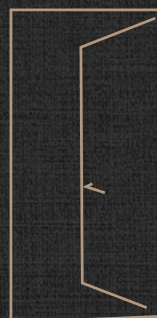

IDENTITY

Guzzini & Fontana è un'azienda italiana che nasce dall'incontro di due imprenditori con una lunga e consolidata esperienza nel settore dell'arredamento. Nata originariamente per arredare la zona notte, prosegue la sua continua evoluzione ampliando la propria offerta con soluzioni dedicate al living. Il concetto alla base della filosofia di GF Interiors è Made with Love in Italy e racchiude passione nella selezione dei materiali, cura nelle lavorazioni artigianali, attenzione per i dettagli e alta capacità tecnica per un prodotto dallo spiccato valore sartoriale.

Guzzini & Fontana is an Italian company that was born from the idea of two entrepreneurs with a very long and consolidated history in interior furnishing. The company was originally established to produce systems for the Night Area, it now continues its evolution by opening to solutions for the Day Area and Living. GF carries on the concept of Made with Love in Italy that stands for passion in materials selection, attention to details, high technical skills that create an industrial product which is as close as possible to bespoke.

WHO IS WHO

Luca Guzzini discende dall'omonima famiglia, nota per la fabbricazione di oggetti di design a uso domestico. È stato presidente della Teuco, marchio di proprietà del Gruppo Guzzini, operante nel comparto della produzione di cabine doccia multifunzione e vasche idromassaggio.

Gary Fontana è un esperto conoscitore del mercato asiatico e di tutte le sue dinamiche interne. Dal 2000, con la sua OC Shanghai, è diventato partner privilegiato di numerose aziende di mobili italiani che hanno scelto di affidargli la distribuzione dei propri prodotti in Cina.

Luca Guzzini is a descendent of the Guzzini family, well known to produce design products for domestic use. He was for long time the President of Teuco Industries, a leading brand owned by the Guzzini Family that produced wellness products for bathroom.

Gary Fontana is an expert of Asian market and all its dynamics. Since 2000 with his company OC Shanghai, he was selected as a privileged partner of several Italian companies of Italian Furniture who have chosen to rely on him for the distribution in China.

CONCEPT

Un catalogo dedicato alla zona giorno in cui il jazz, principale elemento d'ispirazione, si fonde a pieno con la raffinatezza e l'eleganza dei prodotti Guzzini e Fontana. Un vero e proprio percorso introspettivo che prende spunto dal vissuto di un artista jazz alla ricerca del proprio modo di vivere la casa. Si delineano così ambienti dalla spiccata personalità e dall'ipnotico carisma. Per GF Interiors jazz è "libertà di espressione", andare al di là dello spartito per ottenere performance uniche, esattamente come accade nelle collezioni, che sperimentano infinite "variazioni" di materiali, forme e finiture per dare ritmo e sonorità all'abitare contemporaneo.

A catalogue for Day Systems where Jazz is the main matter of inspiration, it perfectly fuses with the amazing sophistication and elegance of Guzzini & Fontana's products. A proper introspective path that is born for the jazz musician's personality to find a unique way of arranging a house. The result is a collection of environments that have a very strong personality and with a hypnotic charisma. Jazz represents for GF INTERIORS's freedom of expression, going beyond the music sheet to obtain unique performances, in the same way this happens in its collections where GF experiments infinite variations of materials, shapes and finishes that give rhythm and sound to an everyday living.

1
10
21

HOUSE OF TRUMPET

2
22
35

HOUSE OF PIANO

4
48
59

HOUSE OF SAX

3
36
47

HOUSE OF HORN

5
60
71

HOUSE OF GUITAR

6
72
85

HOUSE OF TUBA

8
98
109

HOUSE OF CLARINET

7
86
97

HOUSE OF ELECTRIC GUITAR

9
110
121

HOUSE OF VOCALS

10
122
133

HOUSE OF TROMBONES

11
134
141

TECHNICAL DATA

1st STORY. HOUSE OF TRUMPET

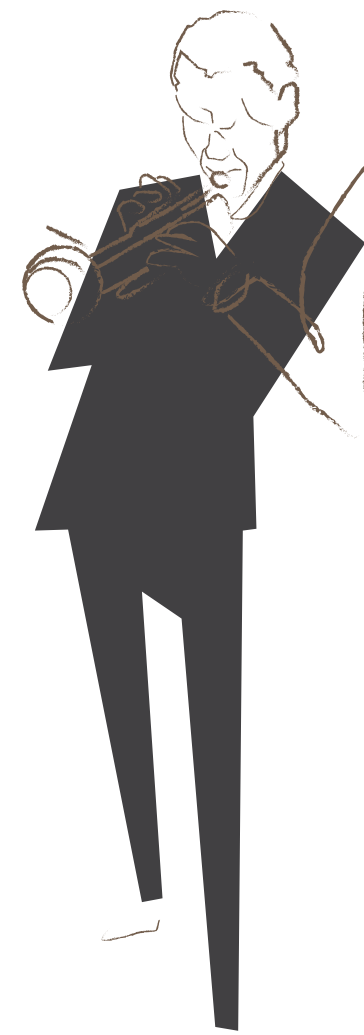



1

"I suoni che escono dalla tromba di un uomo sono parte di lui."

"My whole life, my whole soul, my whole spirit is to blow my horn."

Louis Armstrong



Libreria MISTY in legno Frassino BL con inserti in ottone, mobili contenitori in bilaminato Pietra GR, a seguire armadio Flat con maniglia Reflections bronzo e porta battente ESP Core.

MISTY Library in Frassino BL veneer with brass finish inserts, bilaminated cabinets in Pietra GR, next to it a Flat wardrobe with Reflections handle in bronze finish and ESP Core swing door.



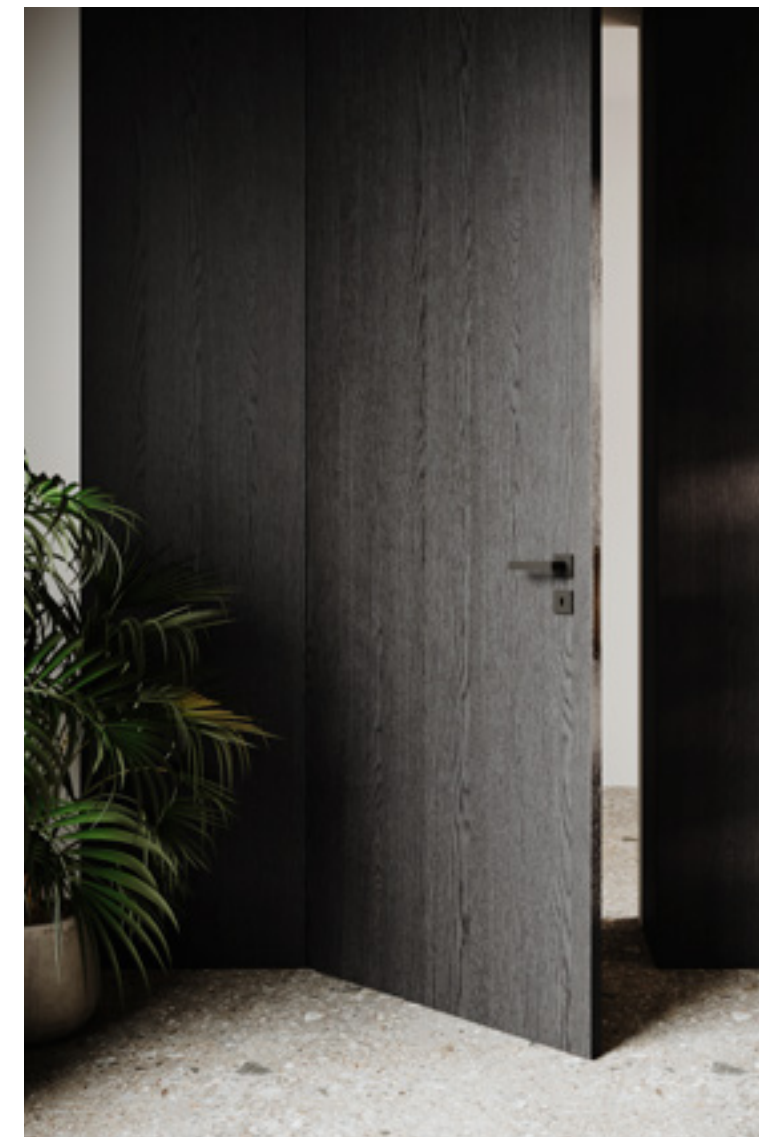

Sistema NAKED in alluminio finitura bronzo e ante in vetro fumé, mobili contenitori in legno Frassino BL. Tavolo con basamento in metallo finitura bronzo e piano gres Marble grey opaco. Sedia BIG MAMA con struttura nero opaco e seduta in velluto grey.

NAKED System in aluminum bronze finish with doors in fumé glass, cabinets in Frassino BL. Table with metal structure in bronze colour and ceramic top Marble-Grey matt finish. BIG MAMA Chair with matt black frame and grey velvet seat.

TECHNICAL DATA

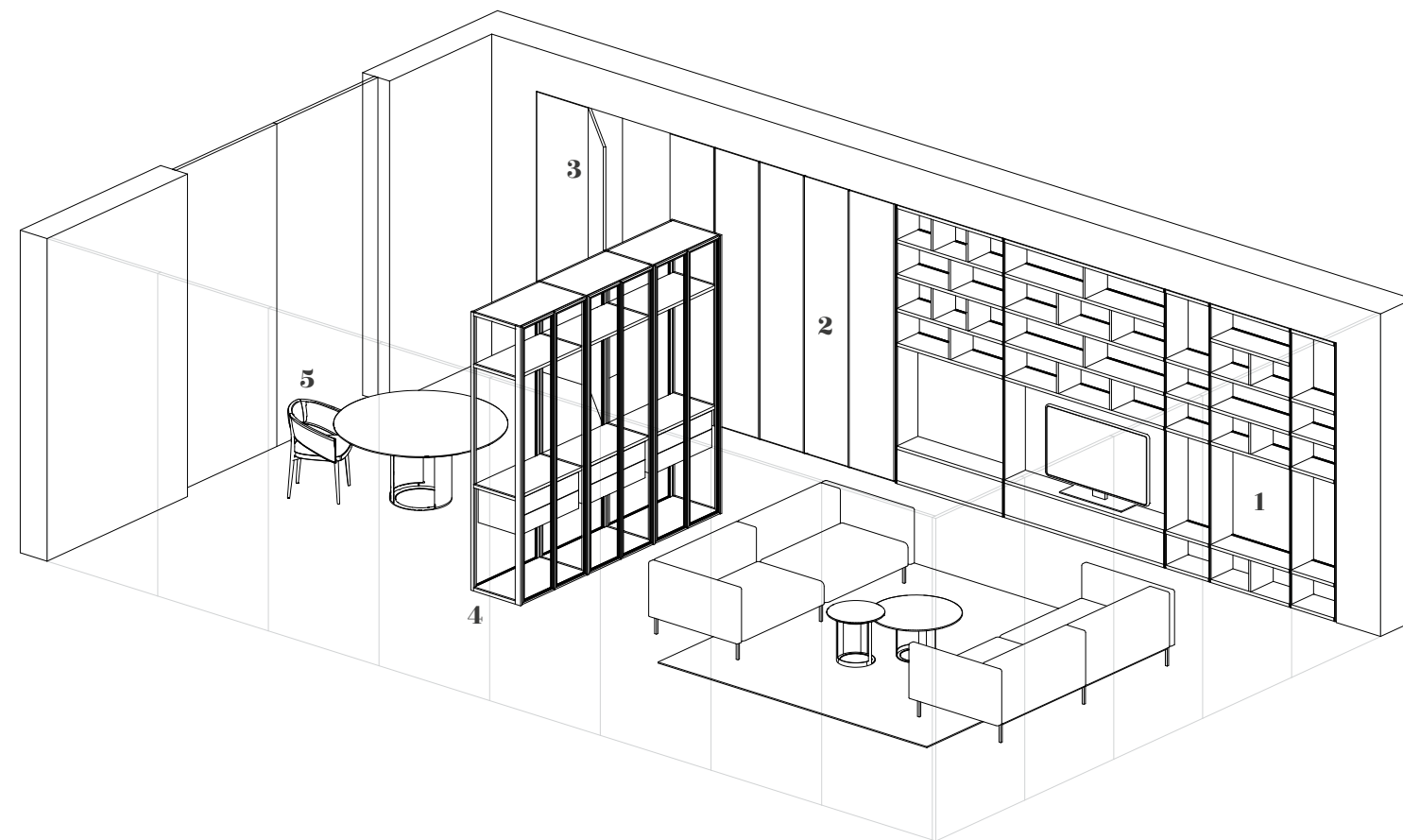
**1** LIBRERIA LIBRARY MISTY

Struttura legno impiallacciato
Frassino BL con profili alluminio
bronzo e ante Bilaminato Pietra GR

Structure in Frassino BL veneer with
brass finish inserts and bilaminate
cabinets in Pietra GR

2 ARMADIO WARDROBE FLAT

Struttura bilaminato Lino Grey e
ante legno impiallacciato Frassino
BL con maniglia Reflections bronzo

Structure in Lino Grey bilaminate
and doors Frassino BL veneer with
Reflections handle in bronze finish

3 PORTA DOOR ESP CORE

Porta legno impiallacciato Frassino BL
con maniglia Robocinques neromat

Door in Frassino BL veneer with
Robocinques handle matt black finish

4 SISTEMA SYSTEM NAKED

Struttura in alluminio finitura bronzo e
legno impiallacciato Frassino BL, ante
alluminio bronzo e vetro fumè

Structure in aluminum bronze finish
and Frassino BL veneer finish, doors in
aluminum bronze finish and fumè glass

5 SEDIA BIG MAMA

Struttura metallo nero opaco e
seduta velluto

Structure matt black finish and grey
velvet seat

2nd STORY. HOUSE OF PIANO



2

“Credo si possa utilizzare il pianoforte come strumento unico capace di esprimere ogni possibile concetto musicale”.

“I believe in using the entire piano as a single instrument capable of expressing every possible musical idea.”

Oscar Peterson

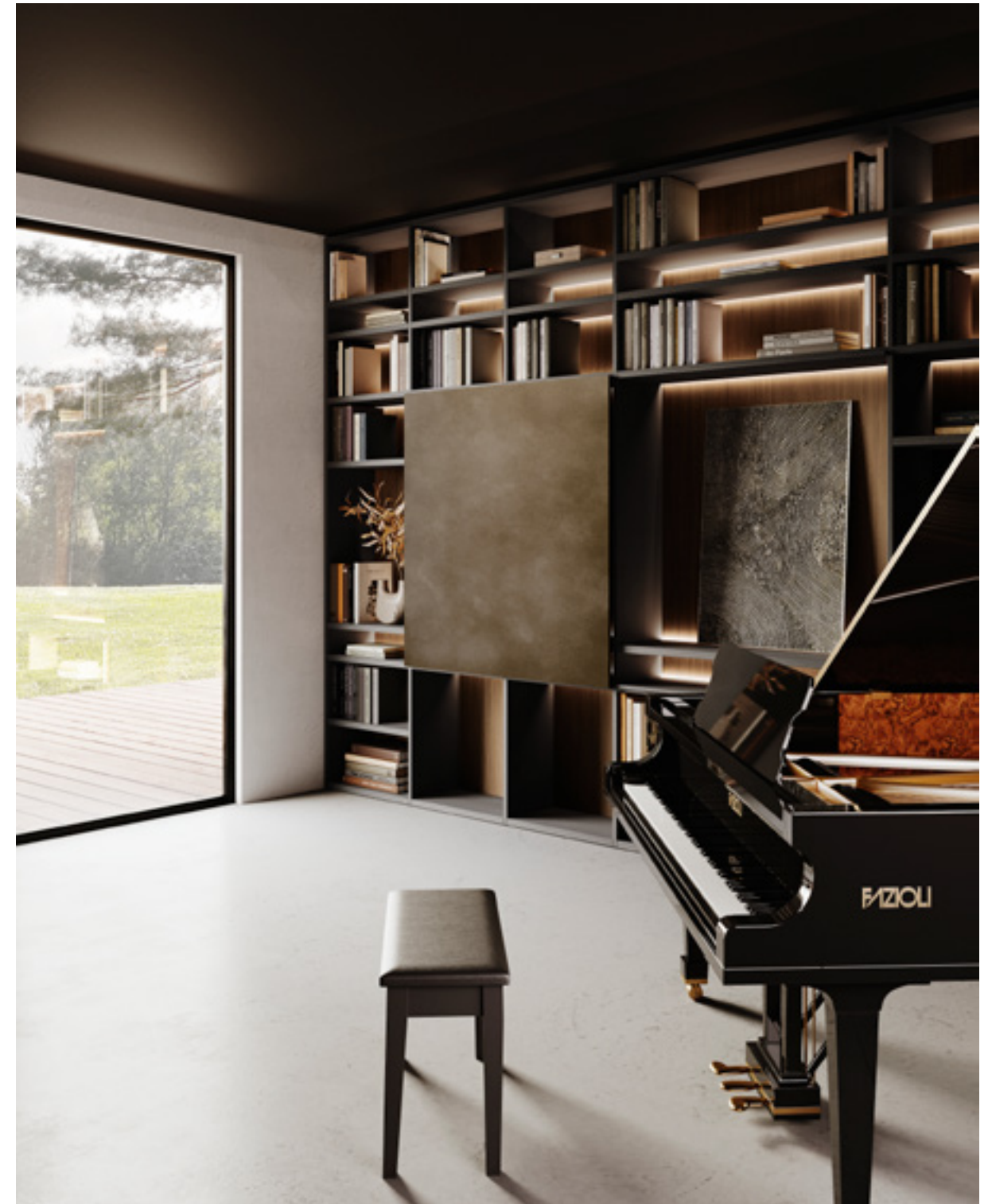





Mobili contenitori in laccato metallico graffiato Brunito con vani aperti e cassetti in pelle. Vetrine NAKED in alluminio nero opaco e vetro fumè. Boiserie in bilaminato legno Mandorlo.

Metal lacquered cabinets in scratched Brunito finish and with open leather units. NAKED glass cabinets in black matt aluminum and fumè glass. Boiserie in Mandorlo bilaminate wood.

Libreria in bilaminato Lino Grey con schiena in bilaminato legno Mandorlo e ante in laccato metallico graffiato Brunito. Media MISTY TRAY con struttura nero opaco e ante in bilaminato legno Mandorlo.

Bilaminato Lino Grey with back panels in Mandorlo wood bilaminate and doors in scratched Brunito lacquer. MISTY TRAY cupboard with black matt aluminum frame. bilaminate doors in Mandorlo.

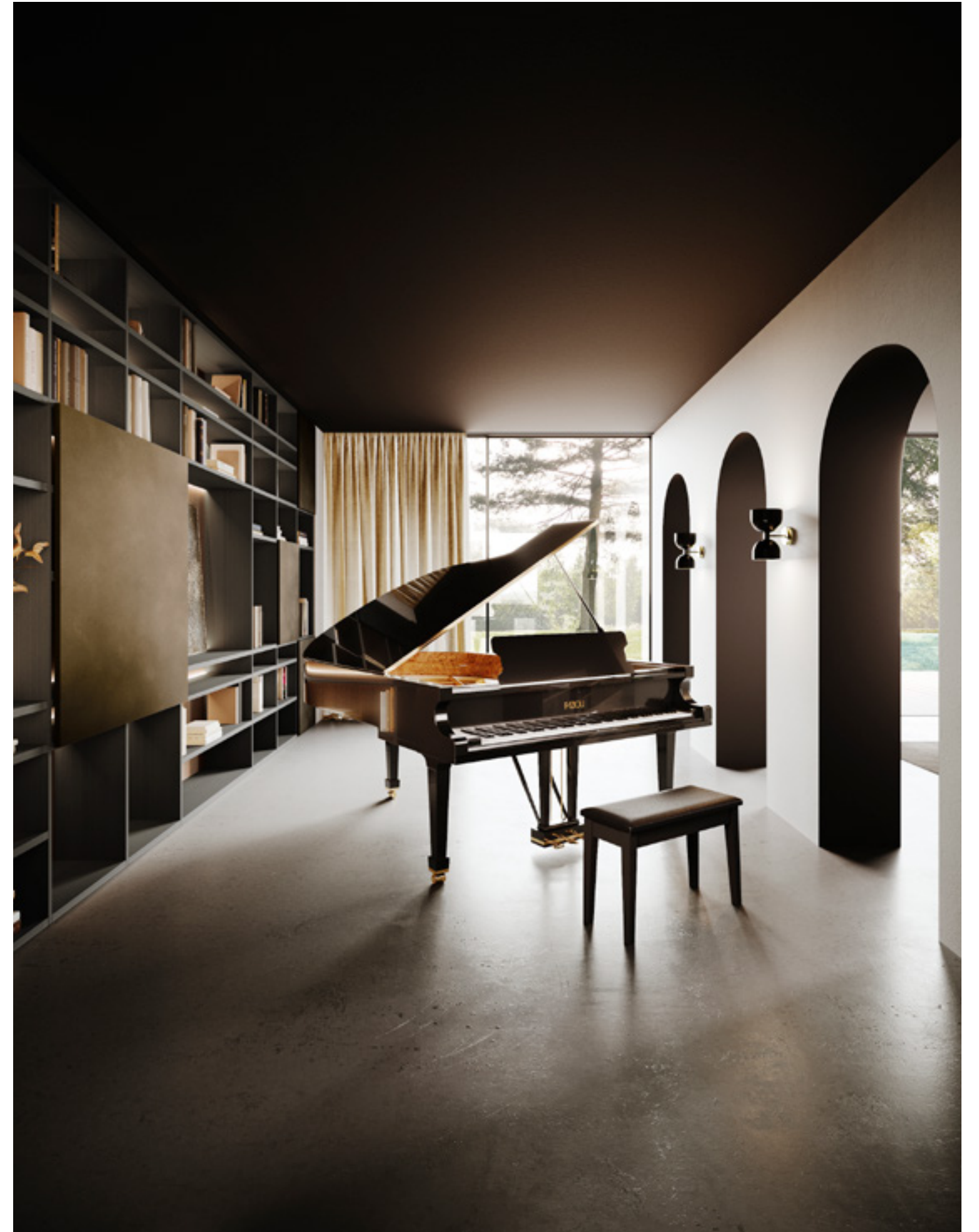

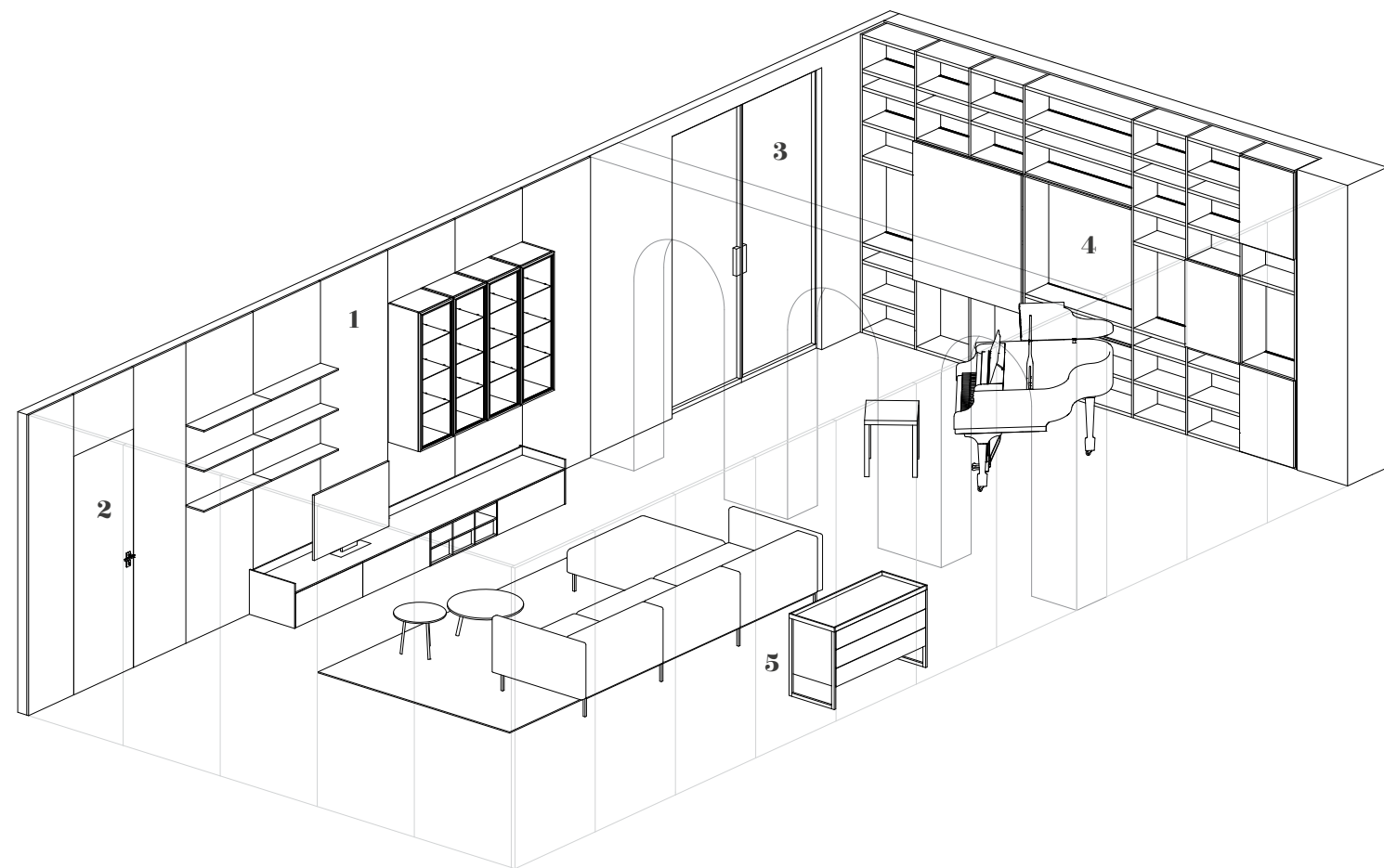

TECHNICAL DATA

**1** LIVING

Struttura bilaminato legno Mandorlo e ante laccato metallo graffiato Brunito, vetrina Naked alluminio nero opaco e vetro fumè

Structure in wood bilaminate Mandorlo finish and doors scratched metal lacquered Brunito finish. Naked glass unit in aluminum matt black finish and fumè glass

2 PORTA DOOR ESP FUSION

Porta bilaminato legno Mandorlo con maniglia Robocinques neromat

Door in wood bilaminate Mandorlo with Robocinques handle matt black finish

3 PORTA DOOR ESP CRISTAL

Porta alluminio nero e vetro extra clear con maniglia Lambda

Door in aluminum black finish and extra clear glass with Lambda handle

4 LIBRERIA LIBRARY

Struttura bilaminato Lino Grey con schienale bilaminato legno Mandorlo e ante laccato metallo graffiato Brunito

Structure in bilaminate Lino grey finish with back panel wood bilaminate Mandorlo finish and scratched metal lacquered Brunito finish doors

5 MADIA SIDEBBOARD MISTY TRAY

Struttura con vassoio in metallo nero opaco e ante bilaminato legno Mandorlo

Structure with tray in matt black finish and doors in wood bilaminate Mandorlo finish

3rd STORY. HOUSE OF HORN

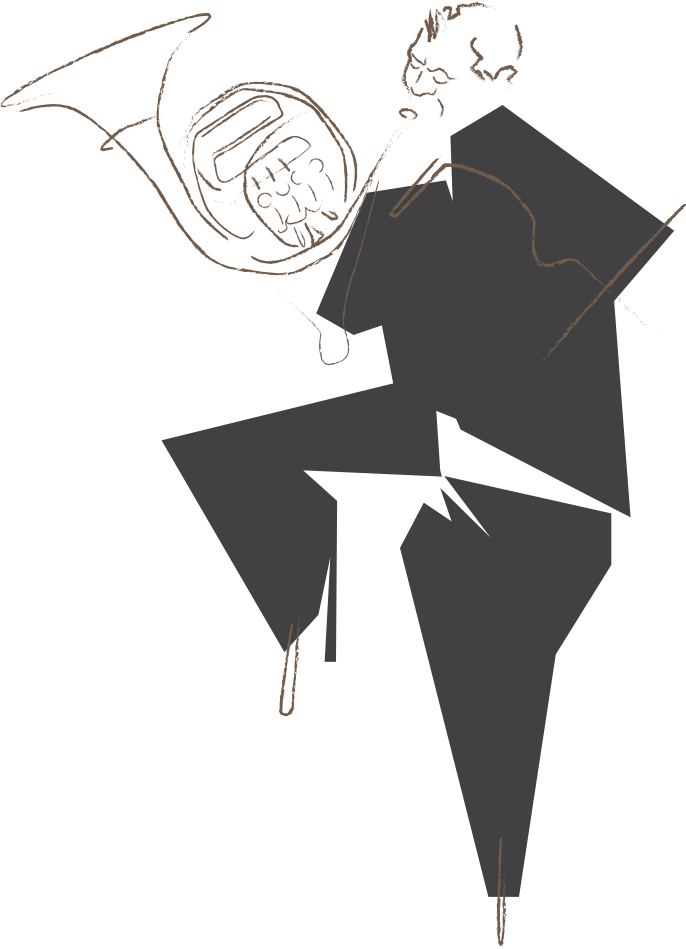



3

"Mi ci è voluta una vita intera per imparare
cosa non suonare"

"It has taken all my life to learn what not
to play"

Dizzy Gillespie





Parete living in laccato opaco Sahara BG, vetrina NAKED con ante in alluminio bronzo e vetro fumé, vano tv in legno Rovere TC e schiena in gres Taj Mahal opaco.

Living system in Matt lacquer Sahara BG, NAKED glass cabinets with doors in Bronze aluminum finish and fumé glass, tv space in veneer Rovere TC and back panel in Taj Mahal matt ceramic surface.

Scrittoio O' DAY con struttura in metallo nero opaco e ante in legno Rovere TC. Tavolo OTIS con basamento in legno Rovere TC rigato e piano in gres Fokos Sale opaco. Sedia BIG MAMA con struttura nero opaco e seduta in velluto grey. Porta scorrevole con telaio alluminio nero opaco e vetro extra clear ESP CRISTAL.

O'DAY desk with metal frame in matt black metal and Rovere TC doors. OTIS Table with striped Rovere TC base and Fokos Sale matt ceramic top. BIG MAMA Chair with matt black frame and grey velvet seat. Sliding door with matt black anodized frame and extra clear glass ESP CRISTAL.

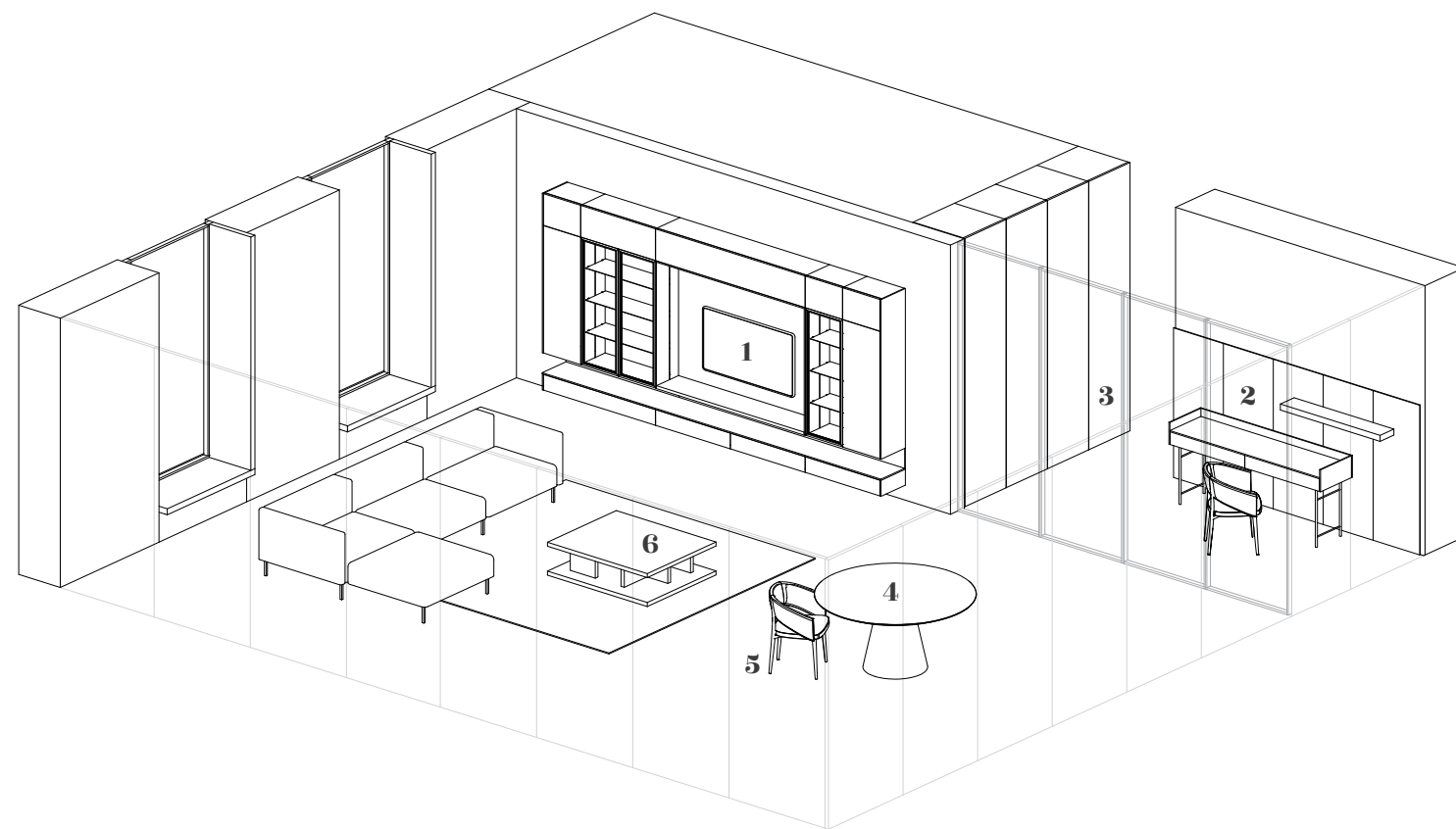

TECHNICAL DATA

**1** LIVING

Struttura bilaminato Lino e ante laccato opaco Sahara BG. Struttura vetrina legno impiallacciato Rovere TC e ante Naked alluminio bronzo e vetro fumè

Structure in bilaminated Lino finish and doors matt lacquered Sahara BG finish. Glass unit structure wood veneer Rovere TC finish and Naked doors in aluminum bronze finish with fumè glass

2 SCRITTOIO DESK O' DAY

Basamento metallo nero opaco con ante e top legno impiallacciato Rovere TC

Structure matt black metal finish with doors and top wood veneer Rovere TC finish

3 PORTA DOOR ESP CRISTAL

Porta alluminio nero e vetro extra clear con maniglia Lambda

Door in aluminum black finish and extra clear glass with Lambda handle

4 TAVOLO TABLE OTIS

Struttura legno impiallacciato Rovere TC rigato e top gres Fokos Sale

Structure in ribbed wood veneer Rovere TC finish and top in gres Fokos Sale finish

5 SEDIA CHAIR BIG MAMA

Struttura metallo nero opaco e seduta velluto

Structure matt black finish and grey velvet seat

6 COFFE TABLE ALFIE

Piano legno impiallacciato Rovere TC e divisori laccato opaco Sahara BG

Top in wood veneer Rovere TC finish and dividers in matt lacquered Sahara BG finish

4th STORY. HOUSE OF SAX



4

"Non suonare il sassofono lascia che sia lui a suonare te."

"Don't play the saxophone. Let it play you."

Charlie Parker







Libreria in legno Noce CN con mobili contenitori in bilaminato Beton VS. Boiserie in legno Noce CN rigato con desk stessa finitura e piano in eco-pelle Pandora 02, vetrina NAKED con ante in alluminio nero e vetro fumé. Coffee table ALFIE con piano in legno Noce CN e divisori in bilaminato Beton VS.

Library in Noce CN veneer with cabinets in Bilaminate Beton VS. Boiserie in striped wood veneer Noce CN with desk in same finish and top in eco-leather Pandora 02, NAKED glass doors cabinet with black matt frame and fumé glass. ALFIE table with Noce CN top and internal divisions in bilaminate Beton VS.

Tavolo YASS con struttura nero opaco e piano in gres Statuarietto opaco. Sedia Big Mama con struttura nero opaco e seduta in velluto grey. Madia STAGE con basamento nero opaco, ante laccato opaco Verde FR e maniglia Noce CN.

YASS Table with matt black structure and top in matt ceramic Statuarietto. Big Mama Chair with matt black frame and grey velvet seat. STAGE Cupboard with matt black basement, lacquered doors Verde FR and Noce CN handles.

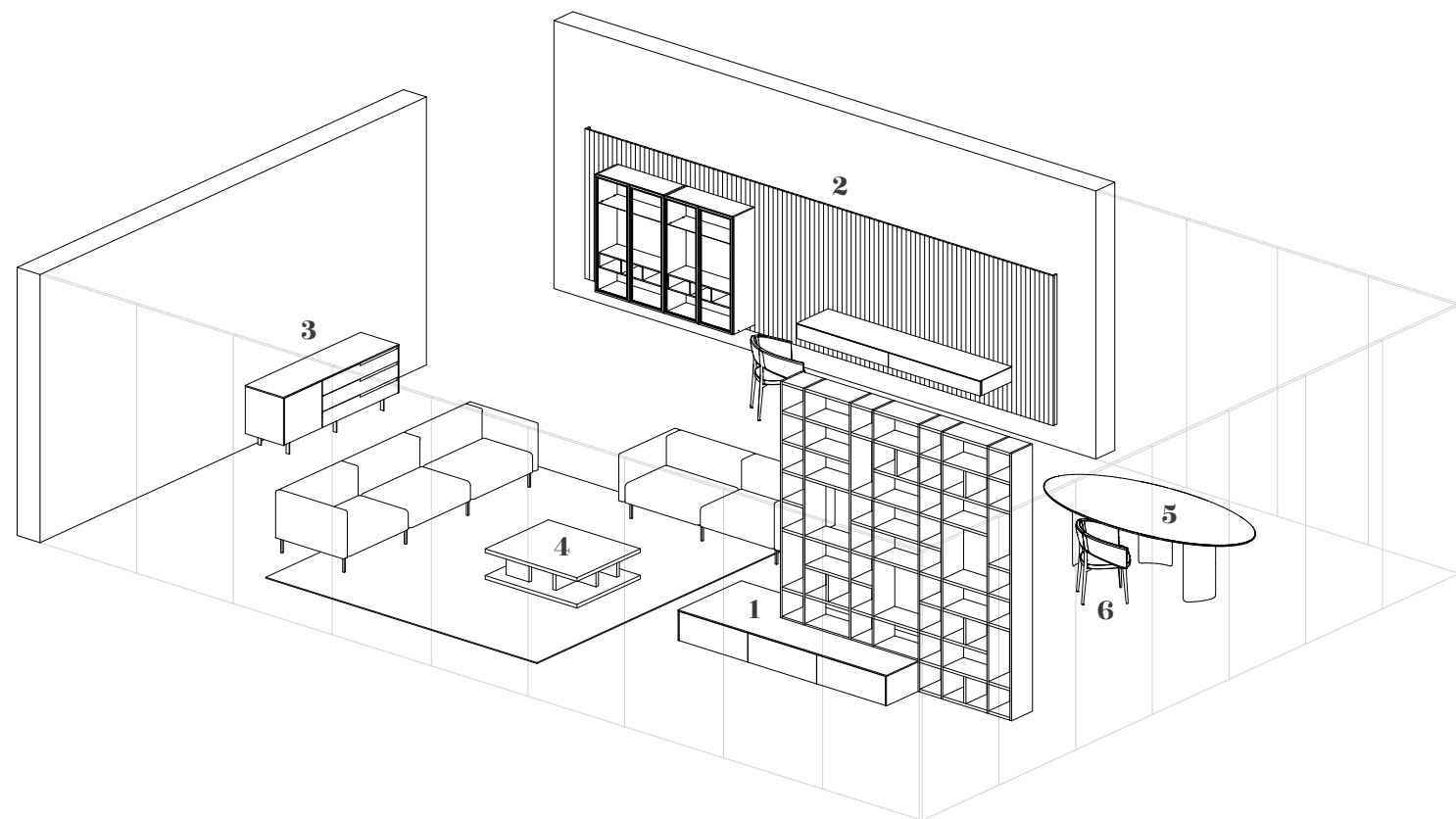

TECHNICAL DATA

**1** LIBRERIA LIBRARY

Struttura legno impiallacciato Noce CN e ante Bilaminato Beton VS

Structure in wood veneer Noce CN finish e doors in bilaminate Beton VS finish

2 LIVING

Boiserie legno impiallacciato Noce CN doge. Struttura vetrina e desk legno impiallacciato Noce CN e ante Naked alluminio nero e vetro fumè. top eco-pelle Pandora O2

Boiserie in striped wood veneer Noce CN finish. Glass unit and desk in wood veneer Noce CN, Naked doors in aluminum black finish and fumè glass. top in eco-leather Pandora O2 finish

3 MADIA SIDEBBOARD STAGE

Basamento metallo nero opaco con ante e top laccato opaco Verde FR con maniglia Noce CN

Structure in metal matt black finish with doors and top matt lacquered Verde FR with handle Noce CN finish

4 COFFE TABLE ALFIE

Piano legno impiallacciato Noce CN e divisori bilaminato Beton VS

Top in wood veneer Noce CN finish and dividers in bilaminate Beton VS finish

5 TAVOLO TABLE YASS

Struttura laccato opaco nero e top gres Statuarietto opaco

Structure in matt lacquered black finish and top in matt gres Statuarietto finish

6 SEDIA CHAIR BIG MAMA

Struttura metallo nero opaco e seduta velluto

Structure matt black finish and grey velvet seat

5th STORY. HOUSE OF GUITAR





5

"Ho sempre voluto collegare la mia chitarra alle emozioni umane"

"I wanted to connect my guitar to human emotions."

B.B. King



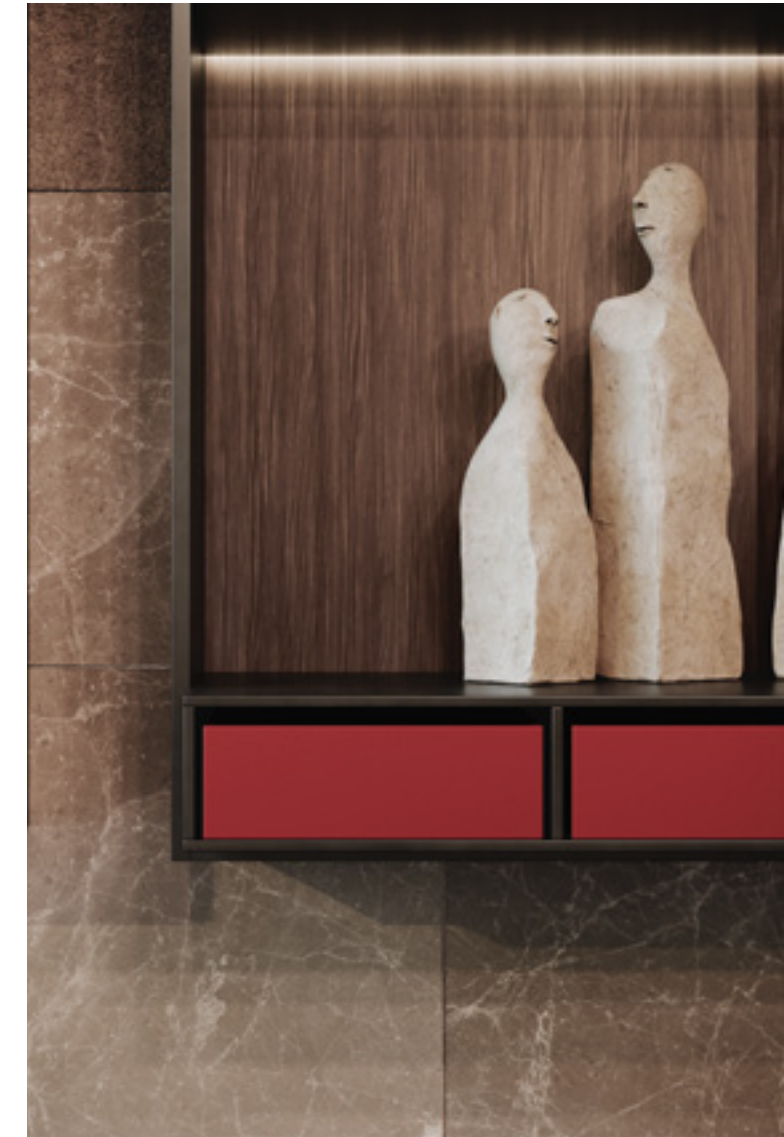

Libreria sospesa in laccato metallico liscio Peltro e schiena in bilaminato legno Mandorlo, cassetti finitura eco-pelle Corfù Rosso.

Suspended library in smooth Metal lacquer Peltro color and back panel in Mandorlo Bilaminate, drawers in eco-leather Corfù Red.

Dettaglio modulo GENTLE con anta scorrevole in finitura laccato metallico liscio Peltro e schiena in bilaminato legno Mandorlo. Tavolo OLIVER con basamento in laccato opaco nero e piano in gres Calce nero opaco. Sedia Big Mama con struttura nero opaco e seduta in velluto grey.

Detail of GENTLE with sliding door in smooth Metal Lacquer Peltro color and bilaminate back panel Mandorlo. Table OLIVER with matt lacquered black basement and grès tabletop Calce Nero matt finish. Big Mama Chair with matt black frame and grey velvet seat.

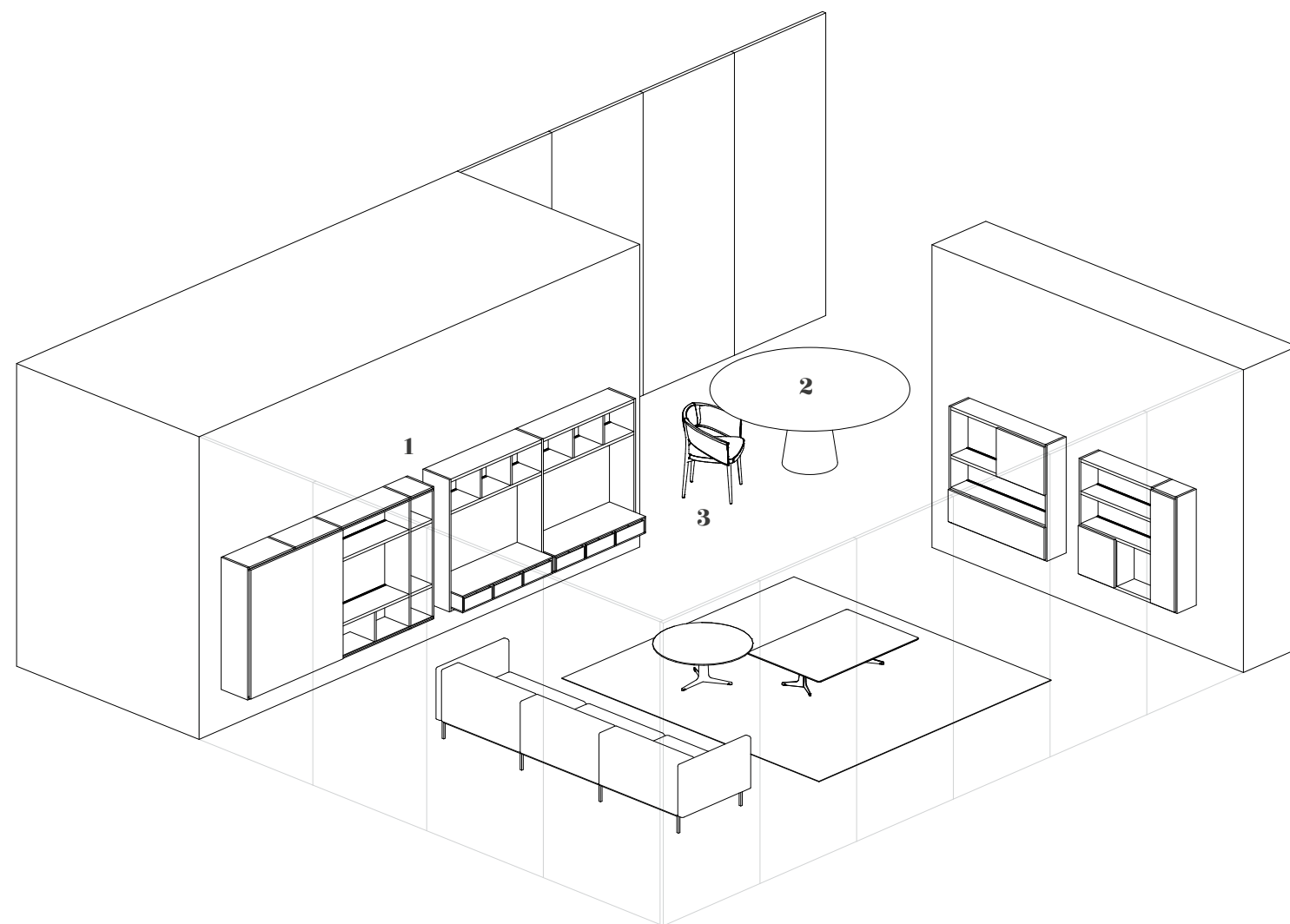

TECHNICAL DATA

**1** LIBRERIA LIBRARY

Struttura e ante laccato metallico liscio Peltro e schiena bilaminato legno Mandorlo, cassetti eco-pelle Corfù red

Structure and doors metal lacquered Peltro finish, back panels in wood bilaminated Mandorlo finish, drawers in eco-leather Corfù red finish

2 TAVOLO TABLE OLIVER

Struttura laccato opaco nero e top gres Calce nero opaco

Structure matt lacquered black finish and top in matt gres Calce nero finish

3 SEDIA CHAIR BIG MAMA

Struttura metallo nero opaco e seduta velluto

Structure matt black finish and grey velvet seat

6th STORY. HOUSE OF TUBA

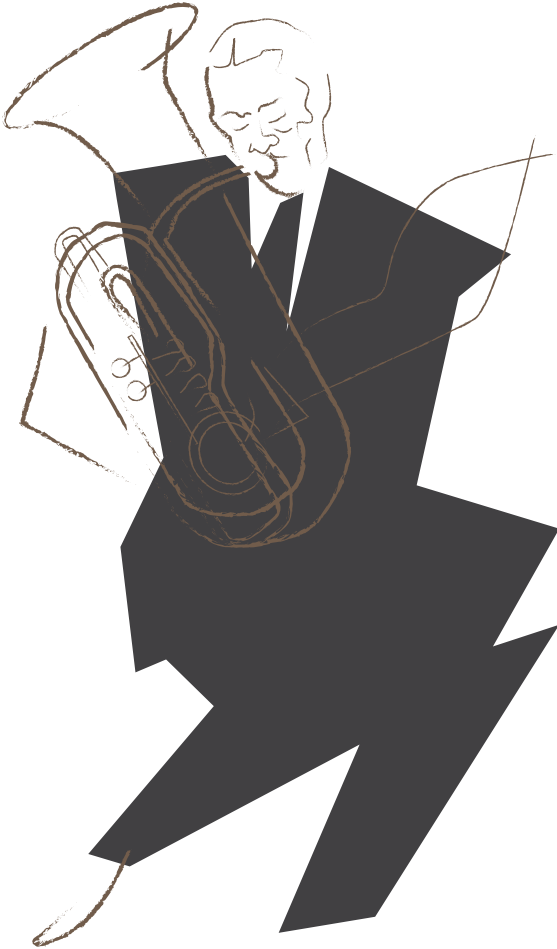



6

"C'è sempre spazio per qualcosa di nuovo"

"There's always room for something new"

Howard Johnson





Parete living in laccato opaco Grigio LV, vetrina NAKED con ante in alluminio nero e vetro fumé, moduli sospesi in laccato opaco Grigio LV rigato e legno Noce CN.

Living system in matt lacquer Grigio LV, NAKED glass doors in black anodized aluminum and fumé glass, suspended wall cabinets Grigio LV lacquered with stripes and Noce CN wood veneer.

Tavolo YASS con struttura nero opaco e piano in gres Emperador opaco. Sedia BIG MAMA con struttura nero opaco e seduta in velluto grey.

YASS table with structure matt black and table-top in gres Emperador matt. BIG MAMA Chair with matt black frame and grey velvet seat.



Madia ELLINGTON & Base con basamento nero opaco, ante laccato opaco Grigio LV rigato e liscio, piano in legno Noce CN.

ELLINGTON & Base Cupboard with matt black legs-frame, doors in Grigio LV lacquer with and without stripes, top in Noce CN veneer.

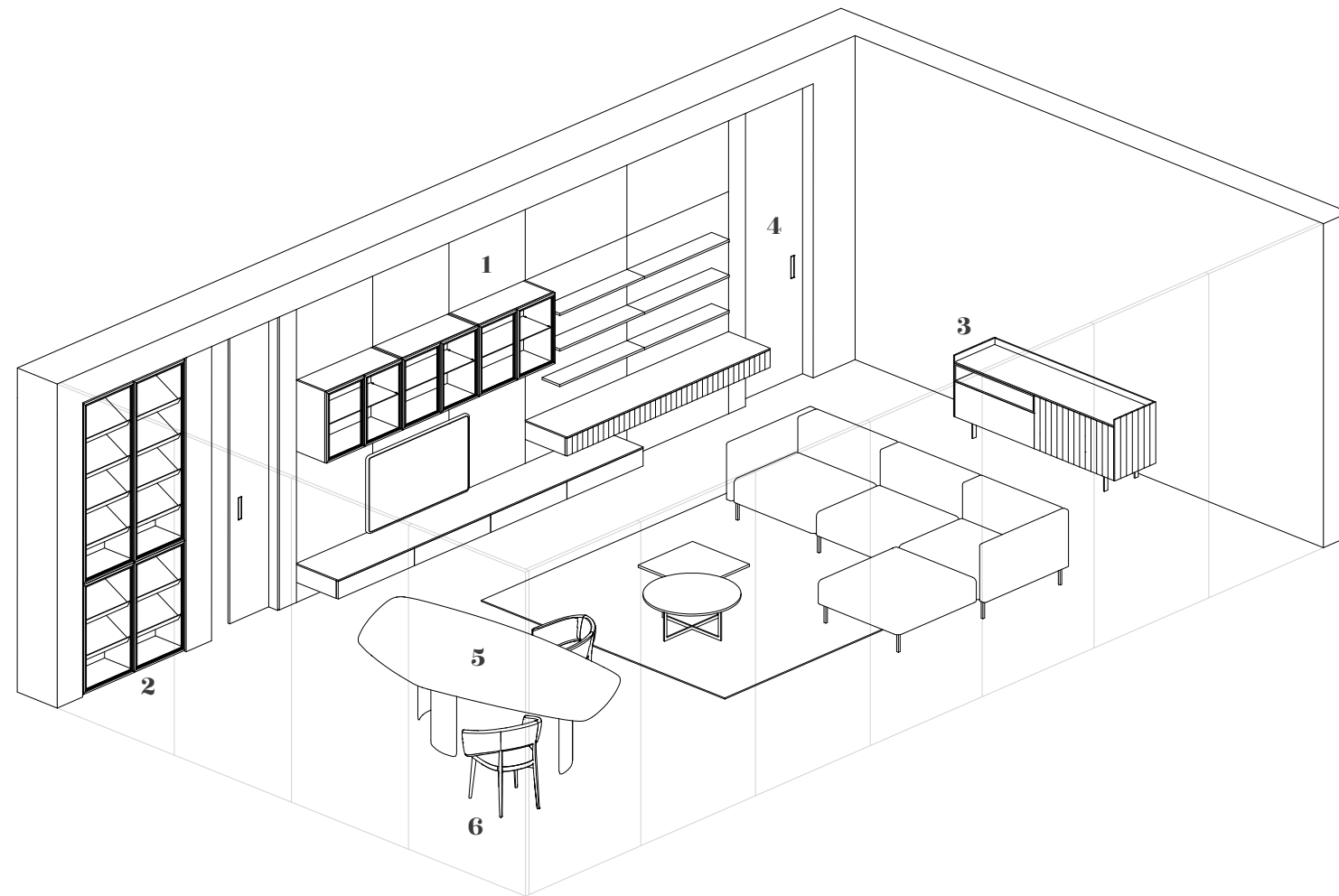

TECHNICAL DATA

**1** LIVING

Boiserie e ante con effetto rigato laccato opaco Grigio LV, boiserie e ante legno impiallacciato Noce CN, vetrina Naked alluminio nero opaco e vetro fumè seamless

Boiserie and doors striped matt lacquered Grigio LV finish, boiserie and doors in wood veneer Noce CN finish, Naked glass unit in aluminum matt black finish and fumè glass seamless

2 CANTINA VINI WINE UNIT

Struttura legno impiallacciato Frassino BL, anta vetrina Naked alluminio nero opaco e vetro fumè seamless

Structure in wood veneer Frassino BL finish, Naked door in aluminum matt black finish and fumè glass seamless

3 MADIA SIDEBBOARD

Basamento metallo nero opaco con ante e top laccato opaco Grigio LV con effetto rigato e legno impiallacciato Noce CN

Structure metal in matt black finish with doors and top matt lacquered Grigio LV with ribbed effect and wood veneer Noce CN finish

5 TAVOLO TABLE YASS

Struttura laccato opaco nero e top gres Emperador opaco

Structure matt lacquered black finish and top in matt gres Emperador finish

4 PORTA DOOR ESP CORE

Porta legno impiallacciato Noce CN con maniglia Hollow

Wood veneer Noce CN finish door with Hollow handle

6 SEDIA CHAIR BIG MAMA

Struttura metallo nero opaco e seduta velluto

Structure matt black finish and grey velvet seat

7th STORY. HOUSE OF ELECTRIC GUITAR





"Per rendere le cose interessanti a volte
accordo la chitarra a caso così da non
poter prevedere cosa ne uscirà"

"Just to keep it interesting I'll tune the
guitar randomly, so I don't know what's
going to come out."

Jim Hall







Libreria in legno Rovere TC, vano tv in gres Fokos Piombo opaco. Vetrina NAKED con ante in alluminio oro rosa e vetro fumè.

Library in Rovere TC, tv cabinet in gres Fokos Piombo opaco. NAKED glass cabinet with aluminum doors in Rose Gold aluminum and fume glass.



Dettaglio Boiserie in legno Rovere TC rigato e porta ESP CORE. Tavolo YASS con struttura nero opaco e piano in gres Emperador opaco. Sedia BIG MAMA con struttura nero opaco e seduta in velluto grey.

Detail of Wall System in. YASS Table with black matt structure and tabletop in gres Emperador matt. BIG MAMA Chair with matt black frame and grey velvet seat.

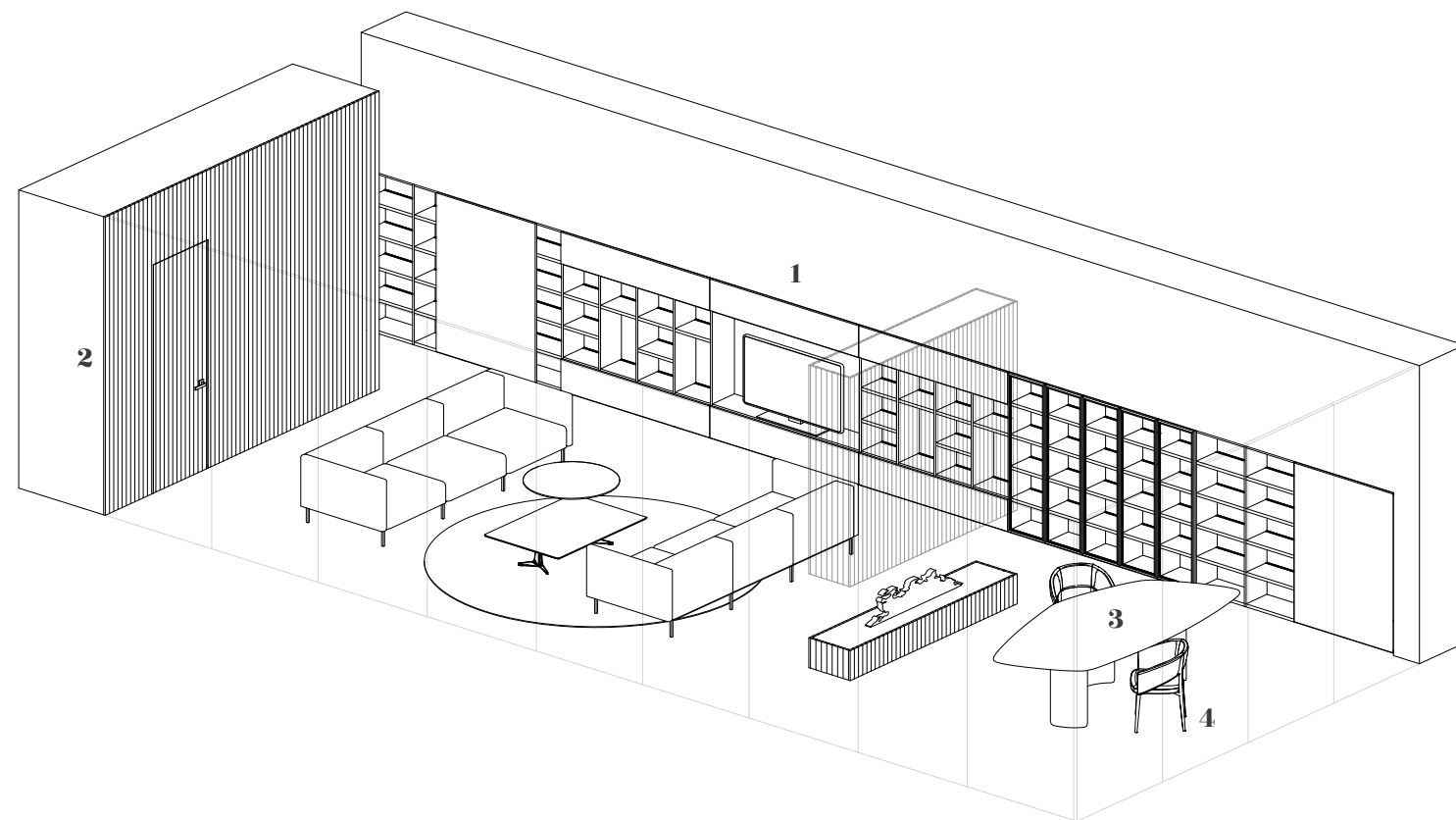

TECHNICAL DATA

**1** LIBRERIA LIBRARY

Struttura e ante legno impiallacciato Rovere TC. Struttura vetrina legno impiallacciato Rovere TC e ante Naked alluminio oro rosa e vetro fumè

Doors in Rovere TC finish, glass cabinet with structure in Rovere TC finish with aluminum doors in Rose Gold finish and fumè glass

2 PORTA DOOR ESP CORE

Porta e boiserie legno impiallacciato Rovere TC doga con maniglia Robocinques neromat

Door with Robocinques handle and boiserie in striped wood veneer Rovere TC finish

3 TAVOLO TABLE YASS

Struttura laccato opaco nero e top gres Emperador opaco

Black matt structure and top in matt gres Emperador finish

4 SEDIA CHAIR BIG MAMA

Struttura metallo nero opaco e seduta velluto

Structure matt black finish and grey velvet seat

8th STORY. HOUSE OF CLARINET



8

"Ho fatto tutto il possibile col clarinetto,
se ci avessi fatto di più lo avrei sminuito"

"I did all you can do with a clarinet. Any
more would have been less."

Artie Shaw







Libreria in legno Rovere FM, mobili contenitori laccato opaco Blu RE e piano in gres Emperador opaco. Coffee table ALFIE con piano in legno Rovere FM e divisori in laccato opaco Blu RE.

Library in veneer Rovere FM, cabinets in Blu RE lacquer and top in Gres Emperador matt. Coffee table ALFIE with top in Rovere FM veneer, dividers in matt Blu RE.

Madia DIVA con basamento nero opaco, ante laccato opaco Blu RE, piano in legno Rovere FM. Scrivania in legno Rovere FM.

DIVA Cupboard with matt black legs-frame, doors in matt lacquer Blu RE, top in Rovere FM veneer, desk in veneer Rovere FM.

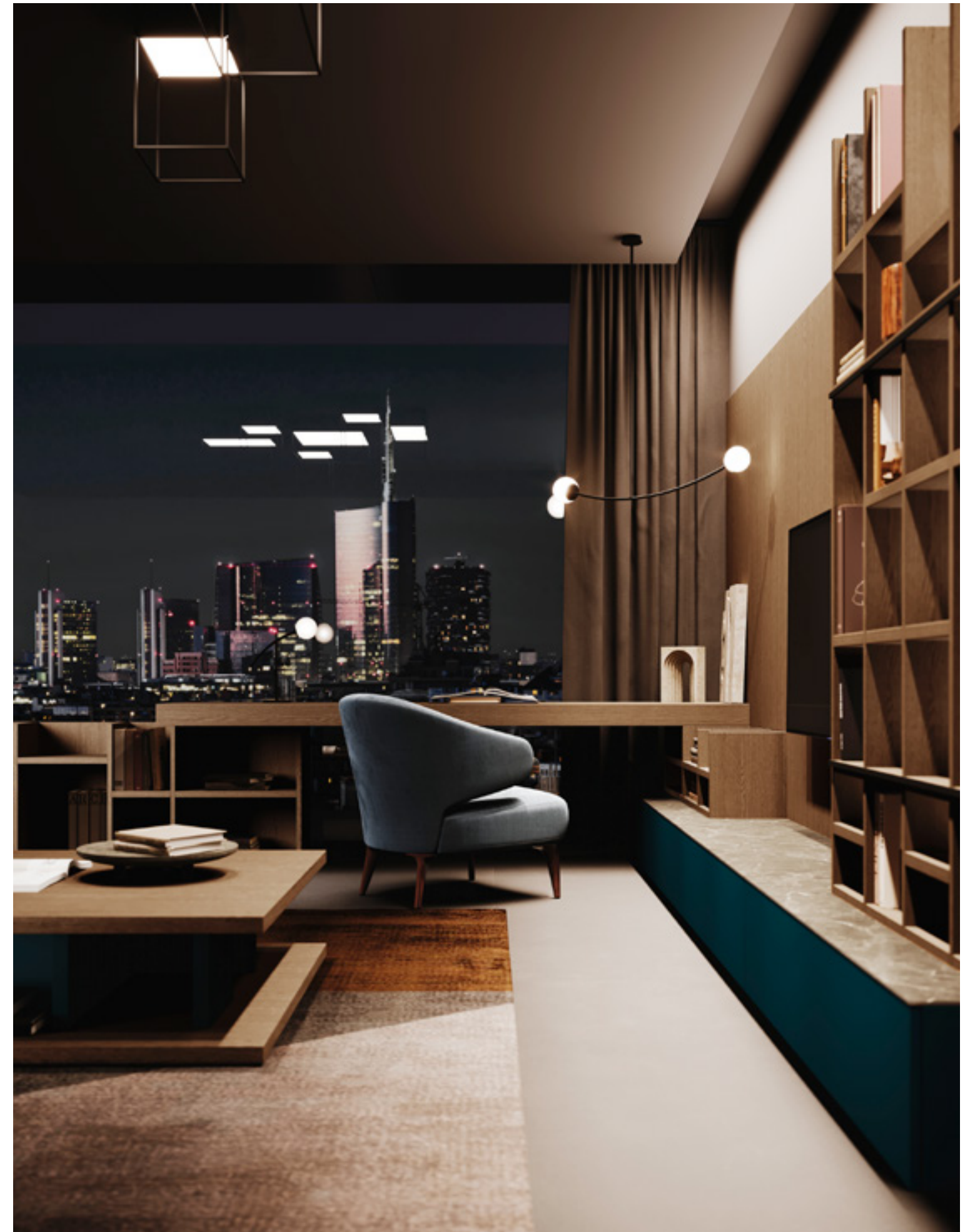

TECHNICAL DATA

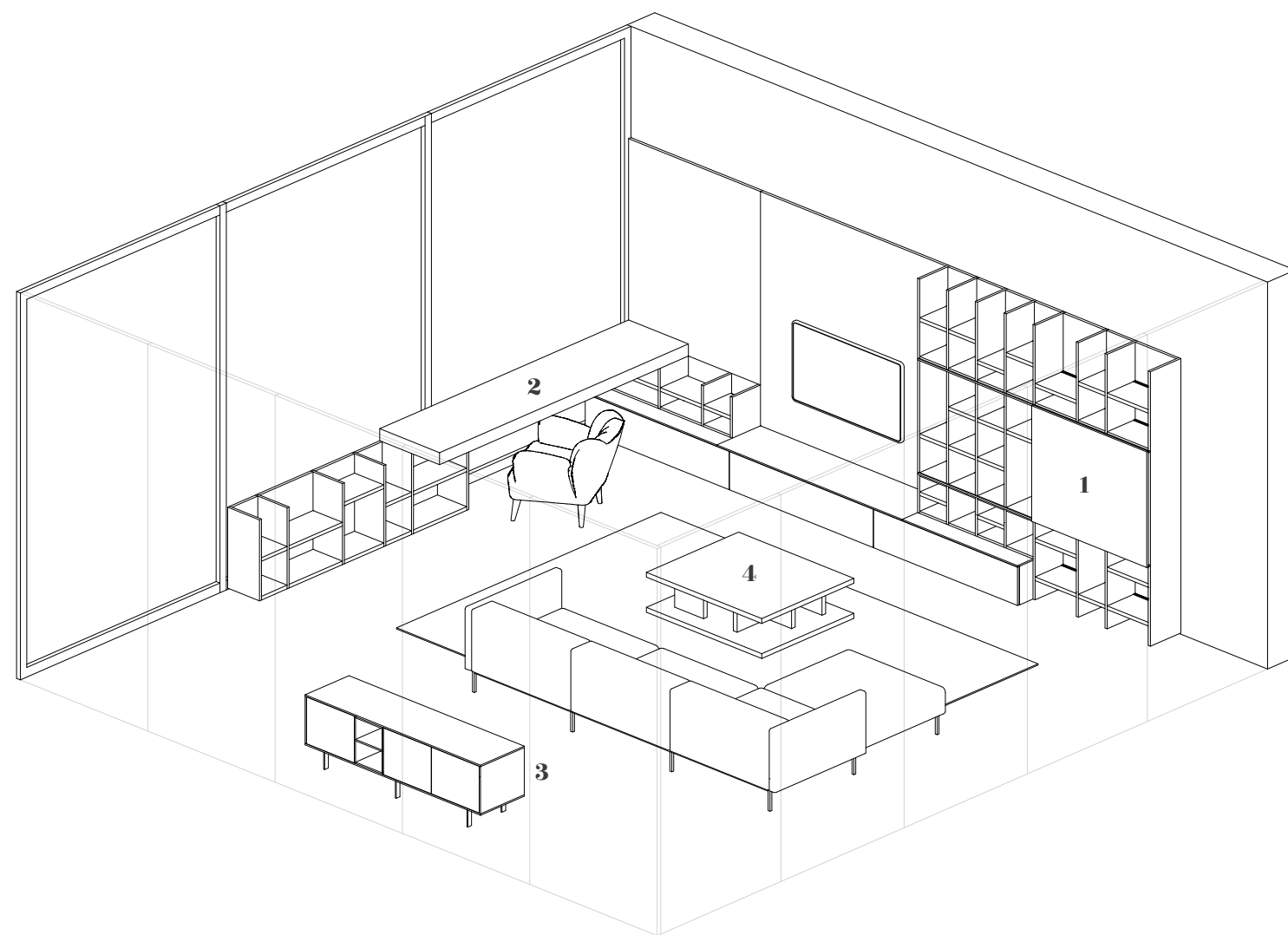
**1** LIBRERIA LIBRARY

Struttura legno impiallacciato Rovere FM e ante laccato opaco Blu RE

Structure in wood veneer Rovere FM finish and doors in matt lacquered Blu RE finish

2 DESK

Piano legno impiallacciato Rovere FM

Desk in wood veneer Rovere FM finish

3 MADIA SIDEBOARD

Basamento metallo nero opaco con ante e top laccato opaco Blu RE e legno impiallacciato Rovere FM

Structure in metal black finish, doors and top in matt lacquered Blu RE finish, open unit in wood veneer Rovere FM finish

4 COFFE TABLE ALFIE

Piano legno impiallacciato Rovere FM e divisori laccato opaco Blu RE

Top in wood veneer Rovere FM finish, dividers in matt lacquered Blu RE finish

9th STORY. HOUSE OF VOCALS





9

"The only thing better than singing is more singing"

"L'unica cosa più bella che cantare è cantare ancora"

Ella Fitzgerald





Libreria laccato opaco Cappuccino LO con schienali legno Rovere VS rigato. Armadio FLAT laccato opaco Cappuccino LO e mobili contenitori laccato opaco Grigio AT rigato.

Library matt lacquer Cappuccino LO with back panels in striped Rovere VS. FLAT wardrobe matt lacquer Cappuccino LO and cabinets with matt lacquer Grigio AT striped.

Madia MISTY TRAY con struttura nero opaco e ante NAKED in alluminio nero e vetro fumè Seamless. Tavolo OTIS con basamento in legno Rovere TC rigato e piano in gres Pietra di Savoia grigio fiammato. Sedia BIG MAMA con struttura nero opaco e seduta in velluto grey.

Misty tray with black matt structure and NAKED doors in black aluminum with fume glass in Seamless pattern. Table OTIS with wood base-ment in striped Rovere TC and tabletop in gres Pietra di Savoia grey veined. BIG MAMA Chair with matt black frame and grey velvet seat.

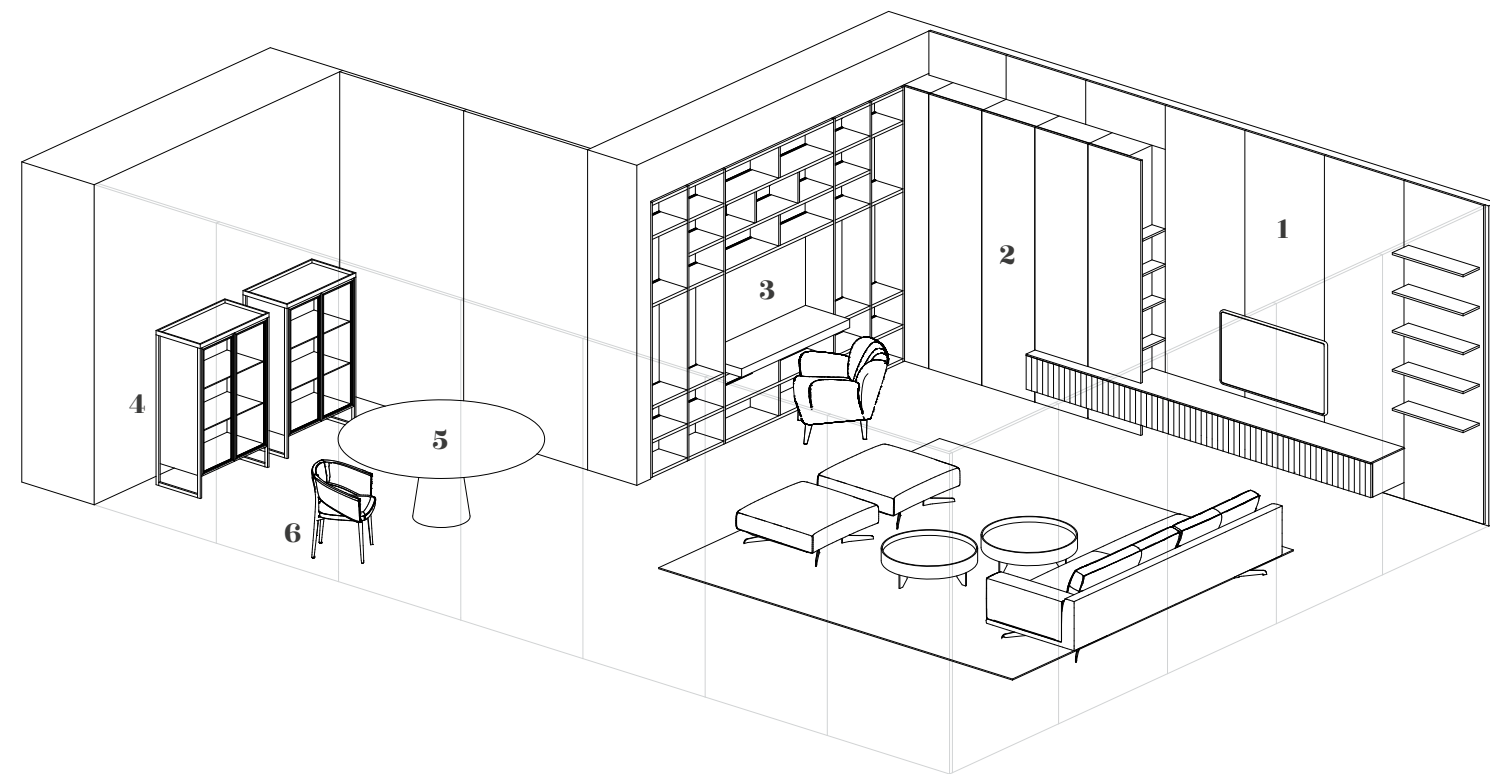

TECHNICAL DATA

**1** LIVING

Struttura bilaminato Lino Grey e ante laccato opaco Grigio AT con effetto rigato. Boiserie legno Rovere VS con effetto rigato

Structure in bilaminato Lino Grey finish and doors with striped effect matt lacquered Grigio AT finish. Boiserie in striped wood veneer Rovere VS finish

2 ARMADIO WARDROBE FLAT

Struttura bilaminato Lino Grey e ante laccato opaco Cappuccino LO

Structure in bilaminato Lino Grey finish and doors matt lacquered Cappuccino LO finish

3 LIBRERIA LIBRARY

Struttura laccato opaco Cappuccino LO, schiene e piano desk legno impiallacciato Rovere VS con effetto rigato

Structure matt lacquered Cappuccino LO finish with back panels in striped wood veneer Rovere VS finish and cabinets with striped matt lacquered Grigio AT finish

4 MADIA SIDEBOARD MISTY TRAY

Struttura con vassoio in metallo nero opaco e ante Naked alluminio nero opaco e vetro fumè seamless

Structure with tray in matt black finish and NAKED doors in black aluminum with fumè glass in seamless pattern

5 TAVOLO TABLE OTIS

Struttura legno Rovere TC rigato e piano in gres Pietra di savoia grigia

Structure in striped wood veneer Rovere TC finish and top in matt gres Pietra di Savoia grey finish

6 SEDIA CHAIR BIG MAMA

Struttura metallo nero opaco e seduta velluto

Structure matt black finish and grey velvet seat

10th STORY. HOUSE OF TROMBONES



10

"Quando soffi da un estremità del trombone dall'altra esce un suono che sconquassa il cosmo"

"You blow in this end of the trombone and sound comes out the other end and disrupts the cosmos."

Roswell Rudd







Libreria in bilaminato legno Mandorlo con ante laccato lucido Caffè OP e vetrine NAKED in alluminio bronzo e vetro fumè, cassetti in eco-pelle Pandora O4 e schienali in gres Stone Brown opaco.

Library in Bilaminate Mandorlo with high gloss lacquer doors in Caffè OP and NAKED glass doors in bronze anodized aluminum and fume glass, drawers in eco-leather Pandora O4 and back panels in matt gres Stone Brown.

Madia ELLINGTON & Base con basamento bronzo, ante laccato lucido Caffè OP, piano in laccato bronzo.

ELLINGTON & Base Cupboard with bronze color legs-frame, doors in Caffè OP, top panel in lacquered bronze.

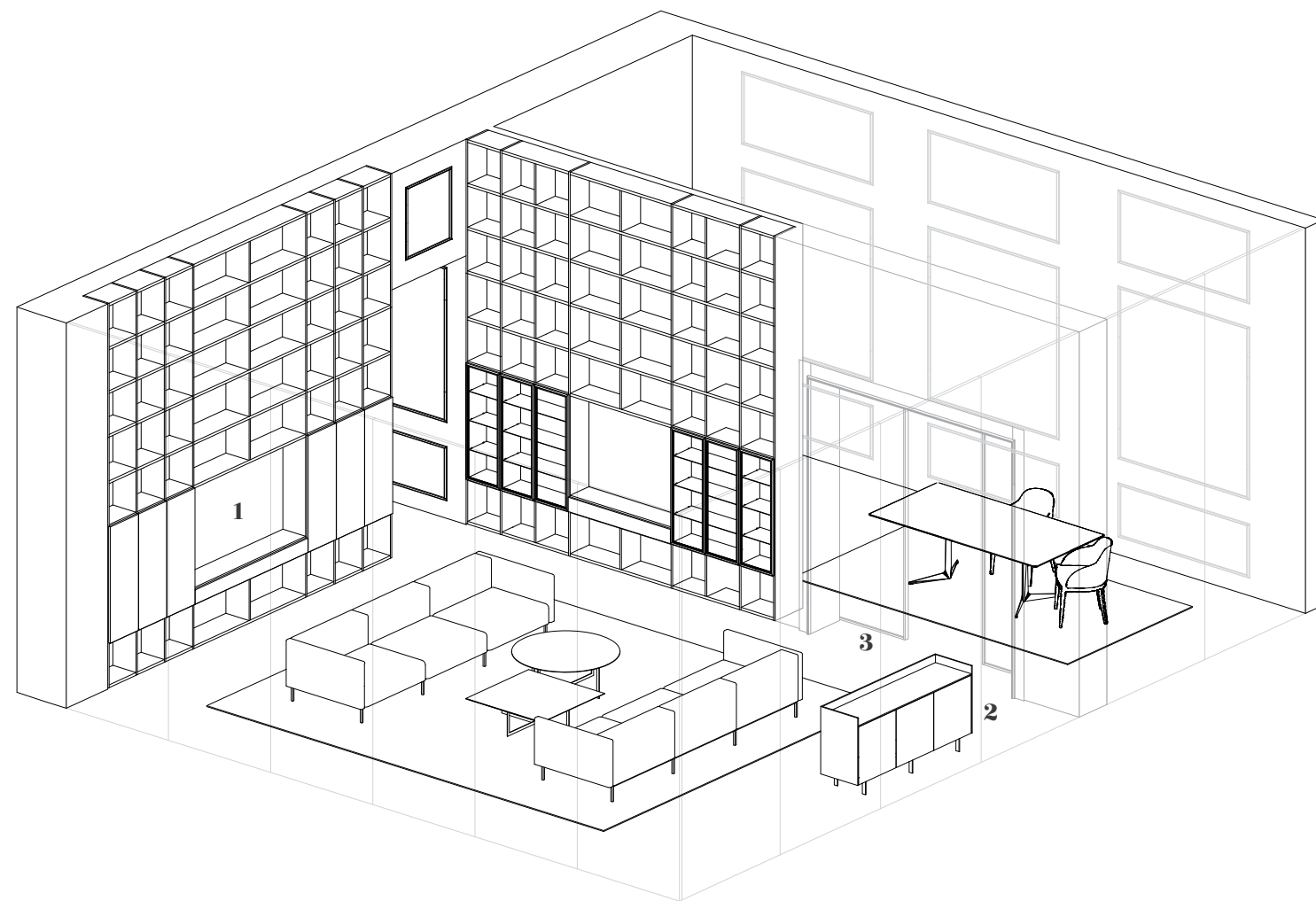

TECHNICAL DATA

**1** LIBRERIA LIBRARY

Struttura bilaminato legno Mandorlo. Ante laccato lucido Caffè OP e eco-pelle Pandora 04. Ante Naked alluminio bronzo e vetro fumè

Structure in wood bilaminated Mandorlo finish. Doors in high gloss lacquered Caffè OP finish and eco-leather Pandora 04 finish. NAKED glass doors in bronze anodized aluminum and fumè glass

2 MADIA SIDEBOARD

Basamento metallo bronzo con ante laccato lucido Caffè OP e top laccato Bronzo

Structure in metal bronze finish with doors in high gloss lacquered Caffè OP finish, top panel in glossy lacquered bronze finish

3 PORTA DOOR ESP CRISTAL

Porta alluminio nero e vetro extra clear con maniglia Lambda

Door in aluminum black finish and extra clear glass with Lambda handle

STRUTTURE STRUCTURES

**STR Bilaminato bilaminato**

Bilaminato materico finitura liscio, tessuto e legno

Materic bilaminato available plain color, fabric or wood finish

**LOP Laccato opaco matt lacquered**

Laccato opaco 6 lati su base bilaminato, disponibile in tutti i colori di serie

Matt lacquered 6 sides on bilaminato panel, available in all price list finishes

**LMT Laccato metallico liscio smooth metal lacquered**

Laccato effetto metallico liscio 6 lati su base bilaminato, disponibile in tutti i colori di serie

Smooth metal lacquered 6 sides on bilaminato panel, available in all price list finishes

Sistema bussolotto - I fianchi di spessore 18 mm vengono forati ogni 160 mm di modo da consentire il posizionamento dei ripiani spostabili. Ogni base è provvista di piede regolabile o attaccaglie. Capello, base e ripiani sono di spessore 18 mm. Schienale di spessore 4 e 8 mm.

Single module system - Side panels thickness 18 mm, hole distance 160 mm for removable shelves. Bottom adjustable feet or hanging system. Top, bottom and shelves thickness 18 mm. Back panels thickness 4 or 8mm.

**LMG Laccato metallico graffiato brushed metal lacquered**

Laccato effetto metallico graffiato 6 lati su base bilaminato, disponibile in tutti i colori di serie

Brushed metal lacquered 6 sides on bilaminato panel, available in all price list finishes

**LEG Impiallacciato wood veneer**

Legno impiallacciato 6 lati, disponibile in tutti i colori di serie

Wood veneer 6 sides, available in all price list finishes

**LEE Impiallacciato esotico exotic wood veneer**

Legno impiallacciato esotico 6 lati, disponibile in tutti i colori di serie

Exotic wood veneer 6 sides, available in all price list finishes

Librerie - I fianchi di spessore 22 mm vengono forati ogni 160 mm di modo da consentire il posizionamento dei ripiani spostabili. Ogni base è provvista di piede regolabile o attaccaglie. Capello, base e ripiani sono di spessore 30 mm. Schienale di spessore 8 mm.

Bookshelves - Side panels thickness 22 mm, hole distance 160 mm for removable shelves. Bottom are equipped with adjustable feet or hanging system. Top, bottom and shelves thickness 30 mm. Back panels thickness 8mm.

MODULARITÀ SISTEMA BUSSOLOTTO MODULARITY

P / D profondità disponibili available depth

Le dimensioni dei mobili sono espresse escluse di ante.

Cabinet dimensions are expressed without doors.

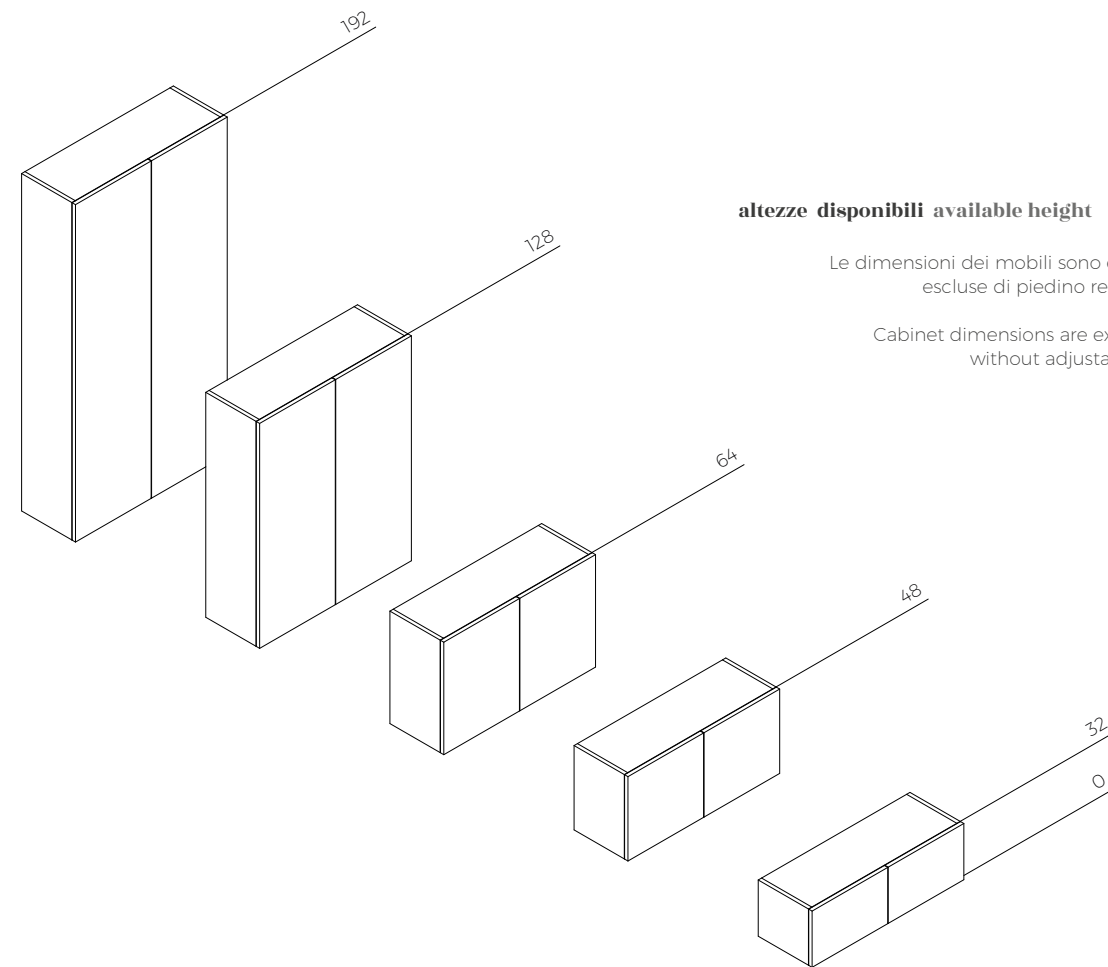
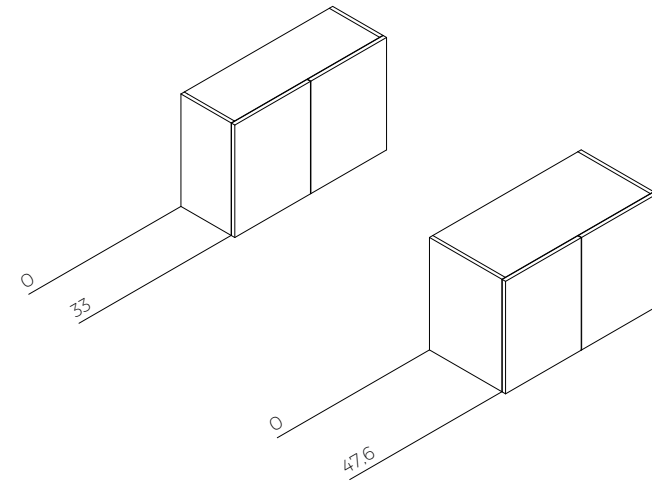

altezze disponibili available height A / H

Le dimensioni dei mobili sono espresse escluse di piedino regolabile.

Cabinet dimensions are expressed without adjustable foot.

larghezze disponibili available width L / W

Le dimensioni dei mobili sono da intendersi comprensive di fianchi.

Wardrobe dimensions are expressed included of side panels.

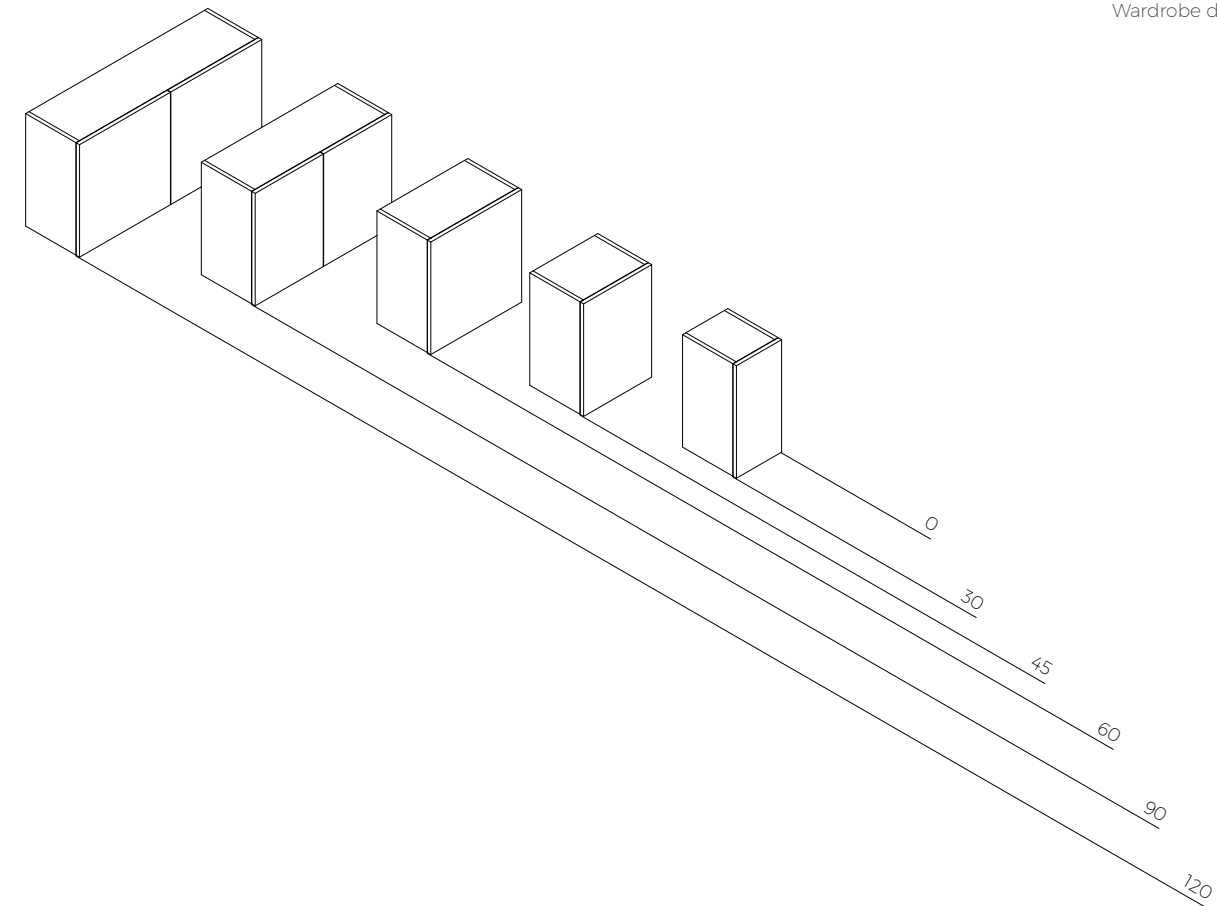

TIPOLOGIE DI APERTURA OPENING SYSTEMS

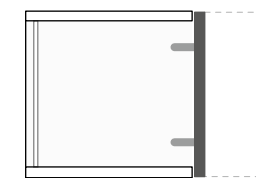

ANTA BATTENTE
hinged door

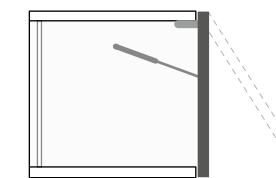

ANTA VASISTAS
vasistas door

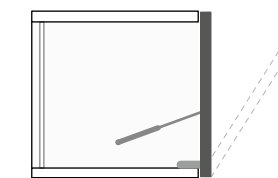

ANTA RIBALTA
flap door

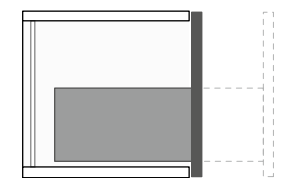

ANTA CASSETTO/CESTONE
drawer/basket door

MODULARITÀ LIBRERIE MODULARITY

P / D profondità disponibili available depth

Le dimensioni dei mobili sono espresse escluse di ante.

Cabinet dimensions are expressed without doors.

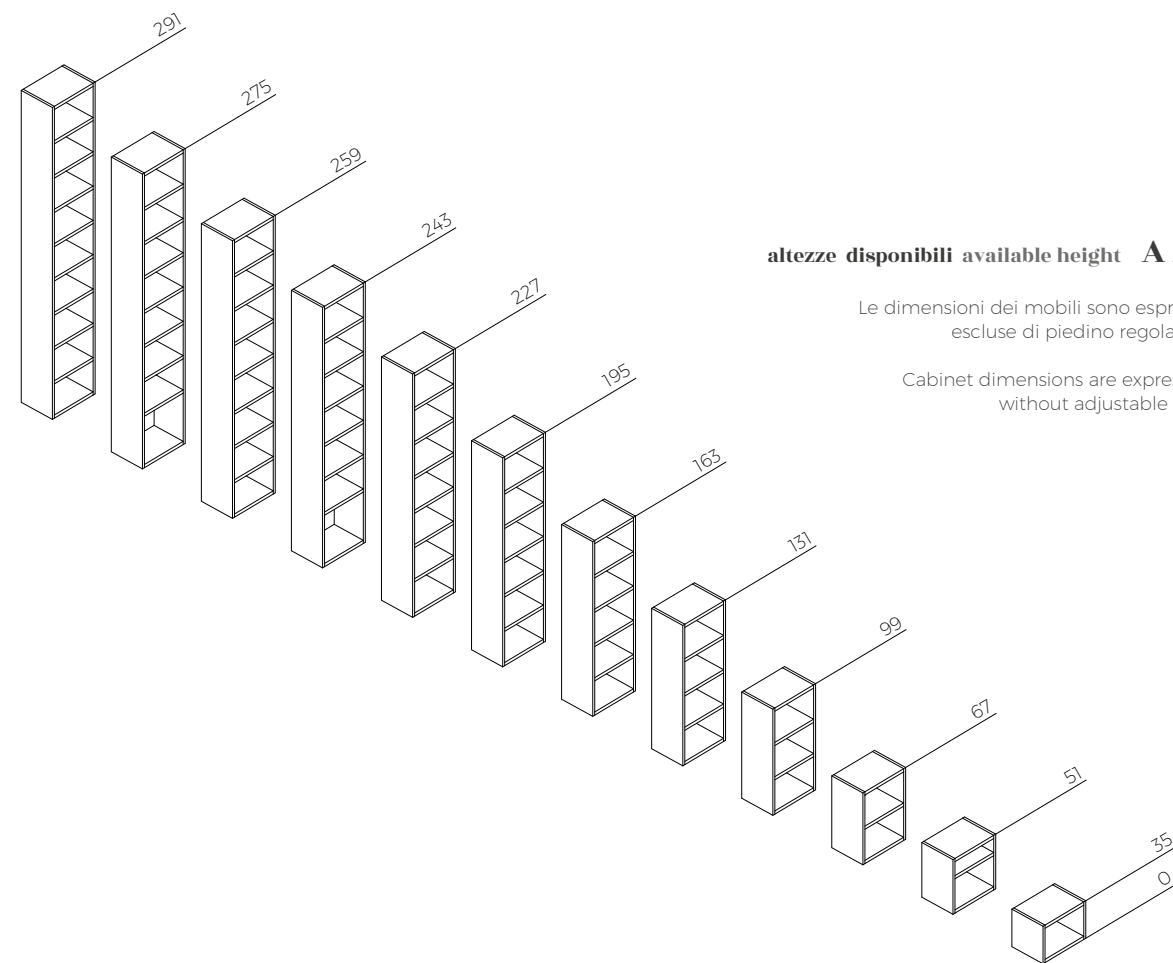
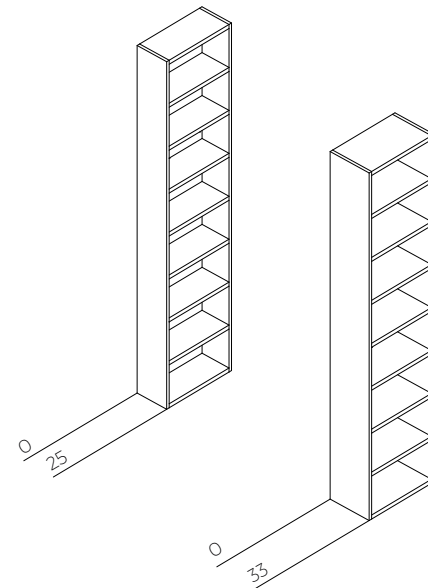

altezze disponibili available height A / H

Le dimensioni dei mobili sono espresse escluse di piedino regolabile.

Cabinet dimensions are expressed without adjustable foot.

larghezze disponibili available width L / W

Le dimensioni dei mobili sono da intendersi per il solo modulo interno, escluso di tramezzi e/o fianchi.

Wardrobe dimensions are expressed only for the internal module, excluded of partition panels and/or side panels.

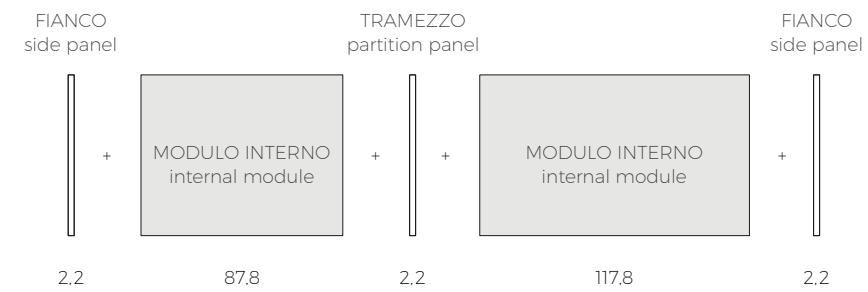
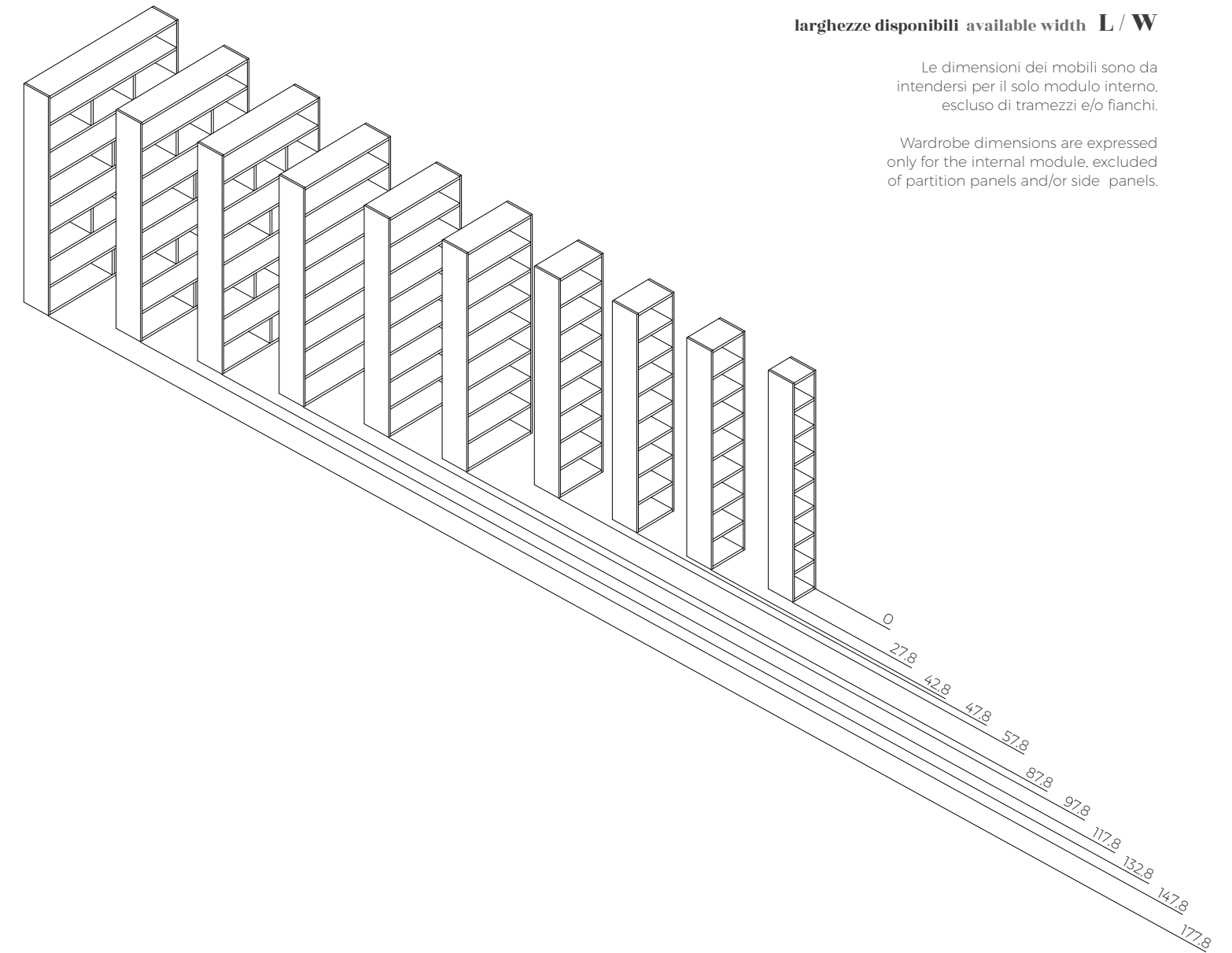

Per progettare la tua composizione aggiungi ai moduli scelti i relativi tramezzi e/o fianchi.

To design your composition, add the relevant partition panels and/or side panels to the chosen modules.

Art direction
Mama Studio

Graphic design
Mama Studio

Product design
Mama Studio
Giuseppe D'Ecclesia

Copy
Mama Studio
Gabriella Cerulli

Render
Matic animation

Color separation
Francesca Di Giovanni

Print
Sincromia

Thanks to
MM Lampadari

GUZZINI & FONTANA PROJECTS S.R.L.
Via Grecia - Palazzese, Roseto degli Abruzzi
64026 (TE) Italy
Cod. Fisc. / P.IVA 01927160679
Tel. +39 085 8069006
info@guzziniefontana.it



The mark of
responsible forestry
FSC® C136814



Guzzini & Fontana project s.r.l. può apportare ai prodotti modifiche, migliorie tecniche, annullamenti di articoli di fine serie che siano ritenuti opportuni, in qualsiasi momento e senza alcun preavviso.
Guzzini & Fontana project s.r.l. reserves the right to modify its products, apply technical improvements or cancel end-of-series articles when deemed opportune and at any time, without prior notice.